



TEAM Round

3482119

TEAM Round - LED 3000K Asymmetrical

Lighting information

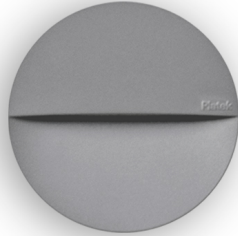

Source power type	LED
Colour temperature	3000K
CRI	>80
MCADAMS	3
LM 80/TM-21	L80B10@>60Kh

Source power	7,20 W
Nominal flux	800 lm

Plug-in power	8,00 W
Real flux	410 lm
Maximum intensity	845 cd/klm
Beam angle	Asymmetrical

Power Supply Unit	220 ÷ 240V
Operating frequency	50/60 Hz
Power factor	1,00
Dimmable	TRIAC
Safety class	I
Wiring	External
Cable section	3 x 1,00 mm ²
Cable length	50 mm;
Cable type	H05RN-F
Connector	IP68 - In line

Protection Rating	IP66
Breaking Strength	IK 09

Energy efficiency class	A/A+/A++
Diffuser type	Transparent methacrylate
Diffuser thickness	2 mm

Colours

Standard colour

● .06 Grey

Colours available on request

● .01 Black

○ .02 White

● .07 Corten

● .08 Anthracite

● .09 Bronze

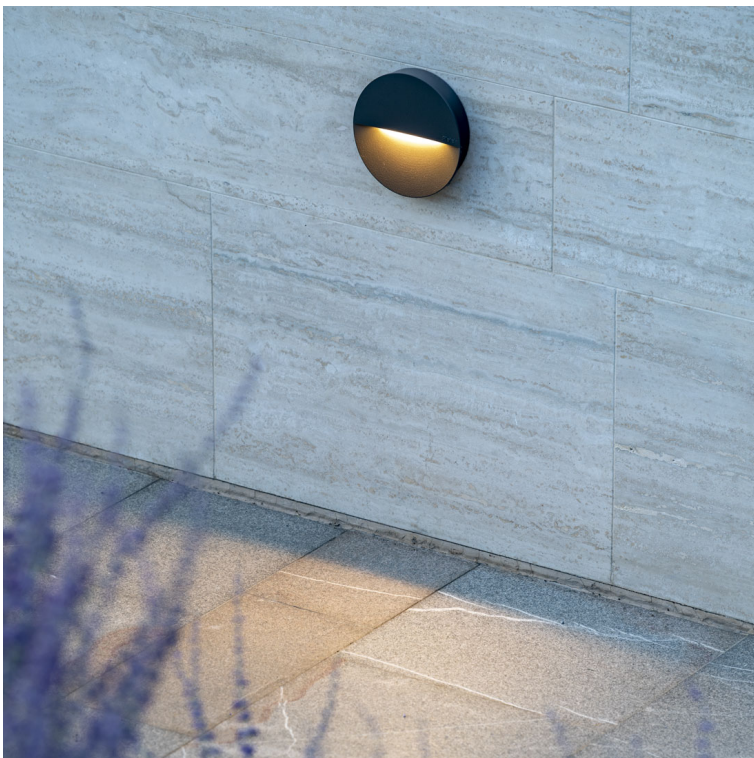

Platek®

PLATEK s.r.l.
Via Paderno, 19 | 25050 Rodengo Saiano (BS) ITALY
P.IVA 03320290178 | Codice fiscale 03007130176
Registro delle Imprese di Brescia n. 03007130176 REA 311057
Capitale sociale Euro 1.000.000,00 i.v. Società con unico socio

Last update:15/02/2022



TEAM Round

3482119

TEAM Round - LED 3000K Asymmetrical

Product features

Front frame and back cover in die-cast aluminium with very low copper content. Wall fixing bracket in painted stainless steel. No visible screws. High luminous efficiency diffusing PMMA lens. This allows to have a high interdistance installation between several fixtures while maintaining uniform illumination. Operating at mains voltage, IP68 connector included. Subjected to galvanic anodizing treatment divided into distinct phases: mechanical satin finishing, surface degreasing, anodic oxidation and final sealing. The product is painted following a continuous two step paint process (epoxy-based primer + polyester-based colour finish), which allows to generate a single thick protective coating which then generates a protective barrier against atmospheric agents and UV rays.

Technical dimensions

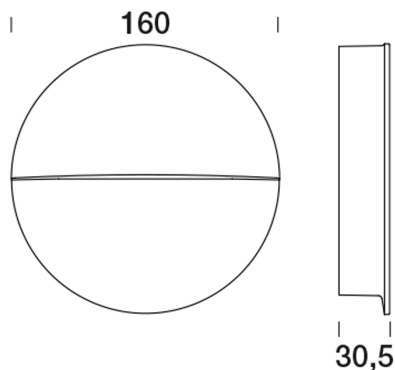

Technical shipping information

Net weight	0,60 kg
Gross weight	0,80 kg
Packaging width	210,00 mm
Packaging height	190,00 mm
Packaging depth	70,00 mm

Lighting information

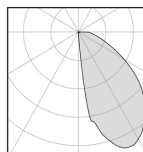

Plug-in power	8,00 W
Real flux	410 lm
Maximum intensity	845 cd/klm
Beam angle	Asymmetrical

Lighting Simulation



Asymmetrical beam angle - TEAM round

simulation made with TEAM Round 8,0 W 3000K

Optics:	Asymmetrical
Code:	3482119
Distance between products:	5 m
Wall height:	1,2 m
Height from wall:	0.6000 m

Plug-in power	8,00 W
Real flux	410 lm
Maximum intensity	845 cd/klm
Beam angle	Asymmetrical

Platek®

PLATEK s.r.l.
Via Paderno, 19 | 25050 Rodengo Saiano (BS) ITALY
P.IVA 03320290178 | Codice fiscale 03007130176
Registro delle Imprese di Brescia n. 03007130176 REA 311057
Capitale sociale Euro 1.000.000,00 i.v. Società con unico socio

Mechanical accessories



8947020
Rubber for side entry cable (2 PCS)

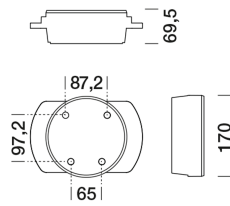

8945128
Recessed box drywall/concrete TEAM round



The process of galvanisation and multi-coating protection

Platek goes well beyond the standards required for conventional protection processes, making use of its longstanding and in-depth expertise in aluminium alloys. All the aluminium components of the products - extruded, die-cast or turned - are subjected to a galvanic anodizing process in the phase following mechanical processing. The process increases their wear resistance and improves the adhesion of the paint. Galvanization involves three distinct phases: mechanical satin finishing and surface degreasing, anodic oxidation and fixing. After the first phase that eliminates any impurities, the aluminium body is immersed in special electrolytic tanks, in which the aluminium surface is transformed into aluminium oxide, which makes the metal more resistant. To respond optimally to the needs of the global market, all Platek products undergo a two-layer painting process. After preparation with washing and rinsing in accordance with the strictest environmental standards, the product is coated with an epoxy primer which guarantees, in addition to anodizing, an excellent degree of protection. The final step is the preparation of the polyester powder which gives the final velvety finish of the component. These last two phases, being done in a continuous cycle, form a single high-thickness layer that is resistant to the action of UV rays and atmospheric agents. This process allows corrosion resistance in salt fog that far exceeds the average standards of the market to be achieved.

The gluing process and plasma treatment

One of the most complex and delicate aspects in outdoor lighting products is the fitting of glass onto the lighting body. This must ensure over time an excellent degree of insulation from atmospheric agents, even in harsh environmental conditions, to maintain a stable performance with zero maintenance. The gluing process of the glass on Platek products is managed at an automated workstation, preceded by a pre-treatment of the surfaces with atmospheric pressure plasma. Pre-treatment modifies the characteristics and ionic properties of the treated surfaces, activates the polar materials at strategic points, removes any residue of detaching agents, such as silicones and oils with a precision microcleaning, favouring excellent wettability of the bonded surfaces and a stable seal in time. The gluing process of the glass with specific plasma treatment allows a bonding force four times greater than similar products to be obtained. The shaping of the surfaces is followed by the application of the silicone and the assembly of the glass onto the lighting body using an automated process that guarantees perfect sealing of the lamp.

Precise LED selection

All LEDs used by Platek, once assembled by trusted personnel are tested with suitable instruments to check the colour specification required by Platek standards. The choice of using only 3 McAdams colour steps and with a CRI value exceeding 90, provide a high level of light quality that is difficult to find in the world of outdoor lighting. As far as LED products are concerned, Platek has adopted a system of protection against electrostatic discharge along the entire production chain of electronic components to increase the resistance of circuits to power surges.